



Manitex
3000 South Austin Avenue
P.O. Box 1609
Georgetown, TX, USA 78627-1609
Telephone 512-942-3000
Facsimile 512-863-3776
www.manitex.com

UPTime is the Manitex commitment to complete support of thousands of units working every day.

UPTime

- Includes 24-7-365 parts shipments.
- Utilizes the efficiency of UPNet online parts order system.
- Relies on Manitex's UPTrak support tracking system for performance analysis and resource allocation.
- Features REMan, Manitex's cost effective rebuild/exchange program.
- Provides expert service technicians for troubleshooting and site visits.
- Mandates training; at our facility and yours. It includes coordinated support from all component suppliers.
- Involves every Manitex team member in the support of every Manitex customer.

What does UPTime mean to Manitex customers?

UPTime means reliability.

UPTime means utilization.

UPTime means profitability.

MTX 3802 • 01.05 • TG • 3,000



features

- **38 Ton (34,5 mton) Capacity**
- **5-Section 124' (37,8 m) Proportional Boom**
- **4-Section 100' (30,5 m) Proportional Boom**
- **3-Section 77' (23,5 m) Proportional Boom**
- **1 and 2-Section 30' 6" (9,3 m) to 55' (16,8 m) Jib**
- **165' 11" (50,6 m) Maximum Tip Height**
- **Continuous Rotation**
- **Retracted, Intermediate and Fully Extended Outrigger Charts are Standard**
- **Pilot Operated Controls with Optional Free Swing**
- **2-Speed Planetary Hoist with Grooved Drum, Negative Draft Flange and Cable Roller. Optional Aux Hoist**
- **Load Moment Indicator with Digital Display, CAN Bus, Overload Shutdown and Internal Boom Length Cable**
- **Radio ATB**
- **Rugged, Weatherproof Electrical System with Circuit Status LEDs**
- **Optional Cab and Heater**
- **System Pressure Gauge**
- **Clamp-On Mounting**
- **Self-Lubricating Slider Pads**
- **Manitex UPTime Comprehensive Support**

series 3802

BOOM TRUCKS



product guide

series 3802

GENERAL SPECIFICATIONS

BOOM

Inverted T-cross section, 3, 4, or 5-section telescoping type, extended and retracted proportionally by a double-acting hydraulic cylinder and cable-crowd system.

38100S/SHL – 4-Section 30' 6" (9,3 m) to 100' 0" (30,5 m). 2-section, 31' (9,5 m) to 55' (16,8 m) jib.

38124S/SHL – 5-section 30' 10" (9,4 m) to 123' 6" (37,6 m). 1-section, 31' (9,5 m) jib.

3877S/SHL – 3-section, 29' 5" (9m) to 77' (23,5m).

Quick Reeve Boom Point – Five high-density nylon load sheaves mounted on heavy-duty roller bearings. Two removable pin-type rope guards.

Boom Elevation – Double-acting hydraulic cylinder. Working range from 10° below horizontal to 80° above.

Load Hook – 5-ton (4,5 mton) capacity hook with heavy-duty swivel and weight is provided for single-line operation.

HOIST

Main Hoist – Maximum theoretical line speed 453 fpm (138 mpm). Maximum theoretical bottom-layer line pull 13050 lb (5 919 kg). Two-speed planetary reducer with wet multi-disc spring applied, pressure-released internal brake and grooved drum.

Optional Aux Hoist - Same as Main

Wire Rope – 380' (115,8 m) of 5/8" (16 mm) diameter rotation resistant type.

SWING SYSTEM

Free swing continuous rotation system. Externally mounted, double-reduction planetary gearbox driven by hydraulic motor. Equipped with a dual brake system; spring-applied hydraulically-released Parking Brake and a foot actuated Dynamic Service brake. Ball-bearing swing circle with external gear. Manitex ACCUSwing control allows operator to adjust crane swing speed up to a maximum of 2.0 rpm.

Free swing not available when crane is equipped with Auxiliary winch option.

OUTRIGGERS

Out-and-down style outriggers, operated independently for precise leveling. Fully extended, intermediate extension and fully retracted positions. 16" (406 mm) diameter floats. Bubble level located near outrigger controls.

MOUNTING

Lower frame is mounted to chassis by threaded rods and clamp plates. No welding, drilling, or bolting to truck frame is required.

Lower Frame – Torsionally resistant, rigid 4-plate design with integrated outriggers and pedestal.

Rear Underride Protection – Supplied on factory-mounted cranes. Fabricated structure mounted under rear of crane. Complies with Bureau Motor Carrier Safety Standard 393.86.

Boom Rest – Heavy-duty fabrication. Easily removed to simplify loading and unloading truck deck.

CONTROL SYSTEM

Single operator platform and seat mounted to turret. Four "pilot operated" single-axis crane controls provide precise metering and multifunction capability. Swing is further refined using Manitex ACCUSwing control to allow setting to individual operator preference. Optional free swing is available to assist in tandem lifting and centering of boom over loads. Controls are arranged in accordance with ANSI B30.5 standards. The operator station also includes engine start/stop, air foot throttle, signal horn, load moment indicator display, boom angle indicator, load chart and range diagram. Enclosed cab and heater are optional.

HYDRAULICS

Hydraulic System – A 3-section pump direct-mounted to power take-off on truck transmission provides 41.7 gpm (158 lpm) to the hoist, 28 gpm (106 lpm) to the boom hoist and telescope circuit, and 12 gpm (45 lpm) to the swing and outrigger

circuit. 100-gallon (379-liter) baffled reservoir includes suction ball valve with strainer and two 25-micron filters in the return line. Use of SAE O-ring and face seal O-ring hydraulic fittings throughout system.

Hydraulic Cylinders – All load-holding cylinders are equipped with integral holding valves.

WARNING SYSTEMS

Load Moment Indicator – CAN bus system maximize expansion capabilities. Senses boom hoist cylinder pressure, boom length and boom angle. Audio-visual warning indicates overload conditions and overload shutoff feature prevents continuing overload. Operator can access all relative crane configuration and load conditions via display at the operator station. Internal boom length cable.

Radio Anti-Two-Block System – Audible warning and shutoff functions prevent hook from contacting boom point. Switch is potted to ensure reliability.

Back-Up Alarm – Supplied on factory-mounted cranes, electronic audible motion alarm activated when truck transmission is in reverse gear.

GENERAL

Electrical – State-of-the-art, weather-resistant components throughout. Automotive style electrical system for easy installation. Designed to withstand high pressure washing and varying climates.

Design/Welding – Design conforms to ANSI B30.5. Welding conforms to AWS D1.1. Tested to SAE 1063 and SAE 765.

Manuals – Operator, service and parts manuals depict correct crane operation, maintenance procedures and parts listing.

Warranty – 12-month warranty covers parts and labor resulting from defects in material and workmanship.

* In order to ensure continuous improvement, specifications may change without notice.

AREA OF OPERATION

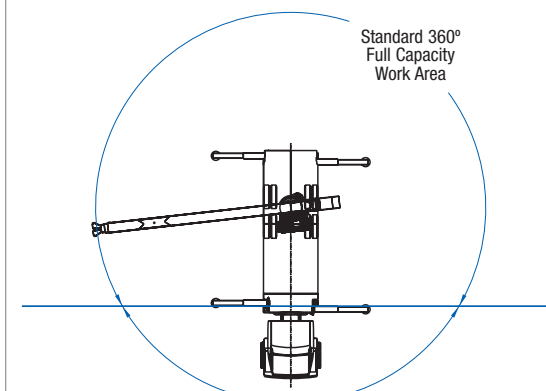

WARNING

The front tires must be in contact with the ground and the machine level when operating in this area.

DEDUCTIONS

Auxiliary Block	50 lb 22,72 kg
Load Block	See block manufacturer nameplate
Overhaul Ball	See overhaul ball manufacturer nameplate
Hose Reel	260 lb 118,18 kg
Swing Around Jib (Stowed)	See load rating chart

ALLOWABLE LINE PULL

1 Part Line	2 Part Line	3 Part Line	4 Part Line	5 Part Line	6 Part Line	7 Part Line	8 Part Line	WARNING
								Anti-two-block system must be in good operating condition before operating crane. Refer to the owner's manual. Keep at least three wraps of load line on the drum at all times.
9,080 lb 4 127 kg	18,160 lb 8 254 kg	27,240 lb 1 238 kg	36,320 lb 16 509 kg	45,400 lb 20 636 kg	54,480 lb 24 763 kg	63,560 lb 28 890 kg	72,640 lb 32 949 kg	
9,500 lb 4 318 kg	19,000 lb 8 636 kg	28,500 lb 12 954 kg	38,000 lb 17 272 kg	47,500 lb 21 590 kg	57,000 lb 25 909 kg	66,500 lb 30 227 kg	76,000 lb 34 473 kg	.625" rot resistant (5.0:1 SF) - 45400 lb. min. breaking strength .625" 6 x 25 IWRC (3.5:1 SF) - 33250 lb. min. breaking strength

BOOM AND JIB COMBINATIONS

3877S/SHL	77'	3 Section Boom	
38100S/SHL	100'	4 Section Boom	31' – 55' 2- Section Jib
38124S/SHL	124'	5 Section Boom	31' 1- Section Jib

USE THIS CHART ONLY WHEN
OUTRIGGERS ARE FULLY EXTENDED.

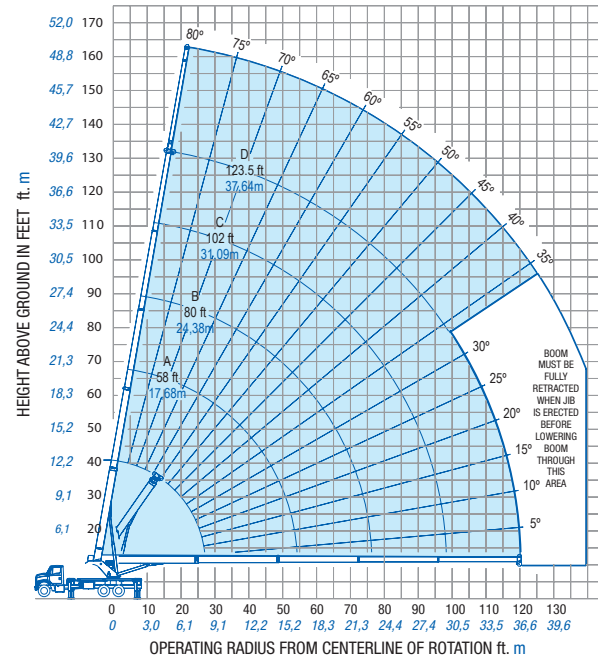
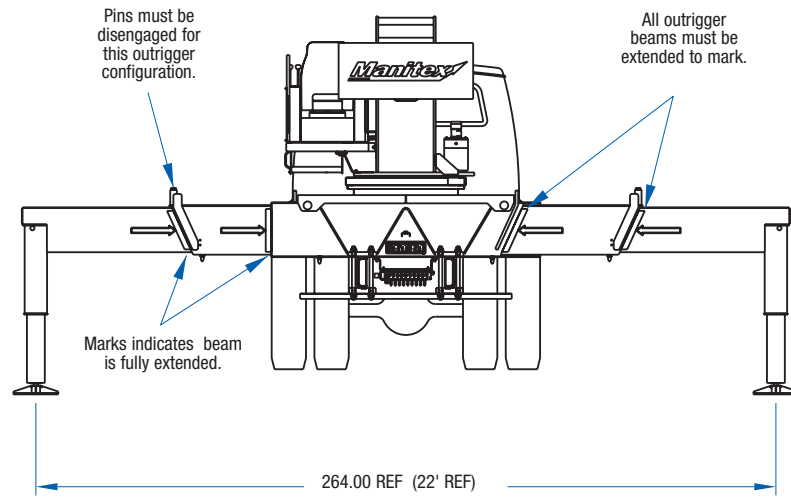

OAH Overall Height
CT Cab to Tandem
CA Cab to Axle
WB Wheel Base
OAL Overall Length
BBC Bumper to Back of Cab
AF Afterframe
EOF End Of Frame

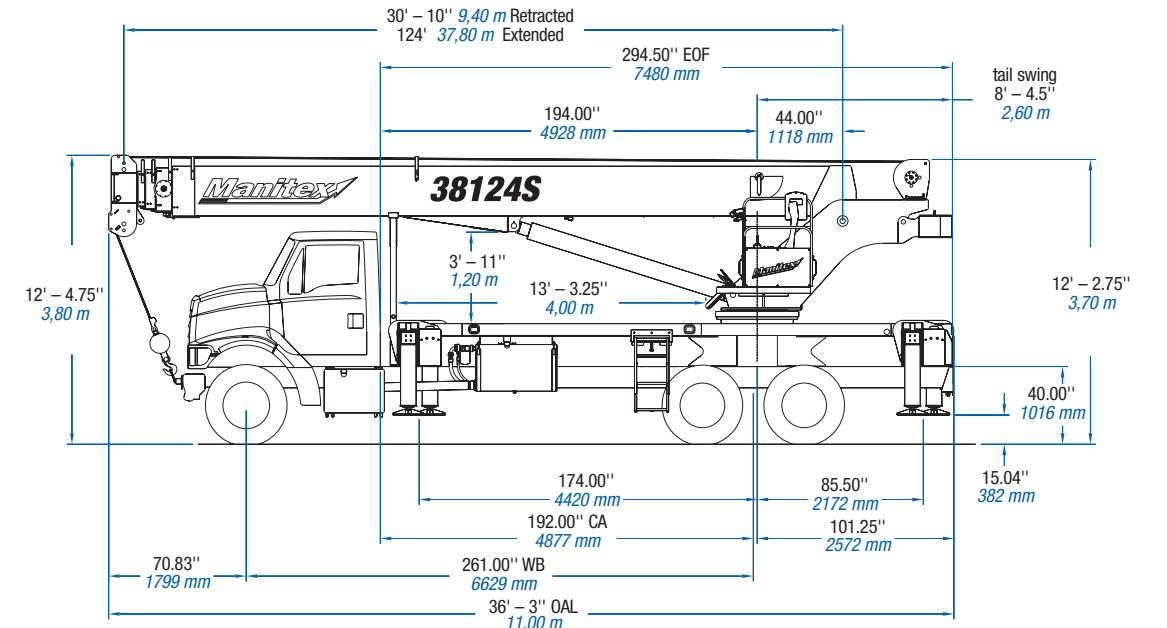

FULLY EXTENDED OUTRIGGER SPREAD: MODEL 38124SHL

MAIN BOOM LOAD RATINGS														JIB						
Operating Radius	Boom Length		A		B		C		D		Fixed Jib		31 Feet 9.45 Meters							
	30.8 Feet 9.40 Meters	58 Feet 17.68 Meters	80 Feet 24.38 Meters	102 Feet 31.09 Meters	123.5 Feet 37.64 Meters															
Feet Meters	lb. kg.	lb. kg.	lb. kg.	lb. kg.	lb. kg.	lb. kg.	lb. kg.	lb. kg.	lb. kg.	lb. kg.	lb. kg.	lb. kg.	lb. kg.	lb. kg.						
5	1,52	75	76,000	34 473																
8	2,44	69	60,500	27 442																
10	3,05	64	52,550	23 836																
12	3,66	60	46,600	21 137	75	25,000	11 340													
15	4,57	53	39,600	17 962	73	25,000	11 340	79	21,500	9 752										
20	6,10	40	31,330	14 211	67	25,000	11 340	75	19,700	8 936	80	14,500	6 577							
25	7,62	22	24,100	10 932	62	22,840	10 360	71	18,200	8 255	77	13,500	6 123	80	8,450	3 833				
30	9,14				56	19,550	8 868	67	16,250	7 371	74	12,820	5 815	78	8,150	3 697	80	4,000	1 814	
35	10,67				49	16,100	7 303	63	14,540	6 595	71	11,380	5 162	75	7,800	3 538	78	3,850	1 746	
40	12,19				42	12,900	5 851	59	13,070	5 928	68	10,160	4 608	72	7,280	3 302	76	3,700	1 678	
45	13,71				34	10,540	4 781	54	10,800	4 899	65	9,370	4 250	70	6,780	3 075	74	3,550	1 610	
50	15,24				23	8,720	3 955	50	9,000	4 082	61	8,430	3 824	67	6,160	2 794	72	3,400	1 542	
55	16,76							44	7,570	3 434	58	7,620	3 456	65	5,540	2 513	70	3,250	1 474	
60	18,28							39	6,400	2 903	54	6,530	2 962	62	5,000	2 268	68	3,080	1 397	
65	19,81							32	5,430	2 463	50	5,570	2 527	59	4,520	2 050	66	2,910	1 320	
70	21,34							24	4,610	2 091	46	4,760	2 159	56	4,090	1 855	64	2,750	1 247	
75	22,86							12	3,900	1 769	42	4,060	1 842	53	3,700	1 678	62	2,600	1 179	
80	24,38										37	3,470	1 574	50	3,350	1 520	60	2,460	1 116	
85	25,91										32	2,940	1 334	47	3,020	1 370	58	2,320	1 052	
90	27,43										25	2,480	1 125	43	2,560	1 161	55	2,170	984	
95	28,96										17	2,060	934	40	2,150	975	53	1,930	875	
100	30,48											35	1,790	812	51	1,720	780			
105	32,00											31	1,460	662	48	1,530	694			
110	33,53											25	1,160	526	45	1,350	612			
115	35,05											18	880	399	43	1,200	544			
120	36,58														40	1,020	463			
125	38,10														36	800	363			
			450 lbs 204 kg			240 lbs 109 kg			180 lbs 82 kg			140 lbs 64 kg			120 lbs 54 kg			DEDUCTIONS FOR STOWED JIB		

Meets ANSI B30.5 Requirements - Do not operate crane or accessories within 10' (3.05m) of live power lines.
NOTICE: This chart is for reference only and must not be used for lifting purposes. Consult factory for other boom options.

CHASSIS DATA	3877S 38100S	38124S	3877SHL/38100SHL 38124SHL
Front Axle Gross Weight Rating	18,000 lb 8 165 kg	20,000 lb 9 072 kg	20,000 lb 9 072 kg
Rear Axle Gross Weight Rating	40,000 lb 18 144 kg	40,000 lb 18 144 kg	44,000 lb 19 958 kg
Minimum Truck Axle Weight - Front**	8,000 lb 3 629 kg	9,200 lb 4 173 kg	9,800 lb 4 445 kg
Minimum Truck Axle Weight - Back**	8,300 lb 3 765 kg	8,300 lb 3 765 kg	8,000 lb 3 629 kg
Nominal Frame Width	34" 864 mm	34" 864 mm	34" 864 mm

CHASSIS DATA	3877S 38100S	38124S	3877SHL/38100SHL 38124SHL
Wheelbase (WB)	261" 6 629 mm	261" 6 629 mm	252" 6 401 mm
Cab to Tandem (CT)	192" 4 877 mm	261" 6 629 mm	187" 4 750 mm
Cab to End of Frame (EOF)	295" 7 493 mm	261" 6 629 mm	271" 6 883 mm
Frame Section Modulus at 180°/360° Area of Operation	25.0 in ³ 110,000 psi 758 422 kPa	261" 6 629 mm	25.0 in ³ 110,000 psi 758 422 kPa

*Frame section modulus at 360° area of operation requires front bumper stabilizer.
**Minimum chassis weight is required to meet 85% stability requirements.
Chassis data is general - not for engineering. Some dimensions depend on truck selection.

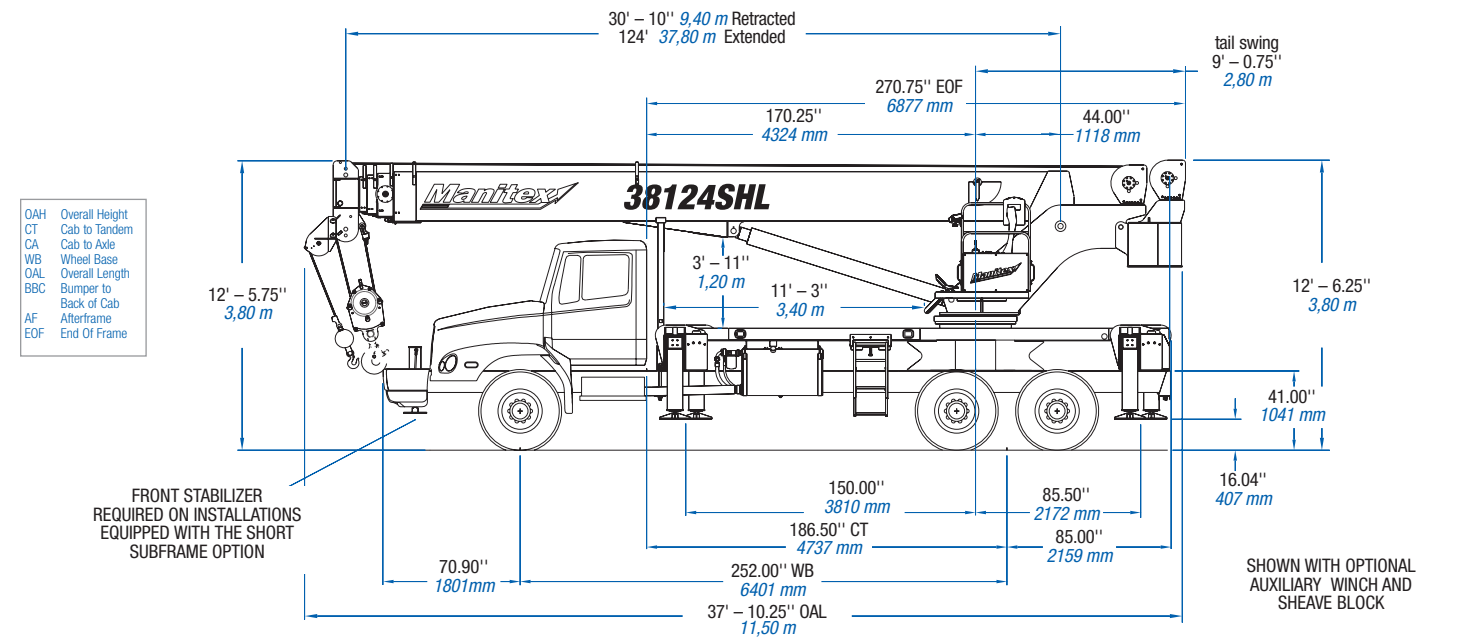

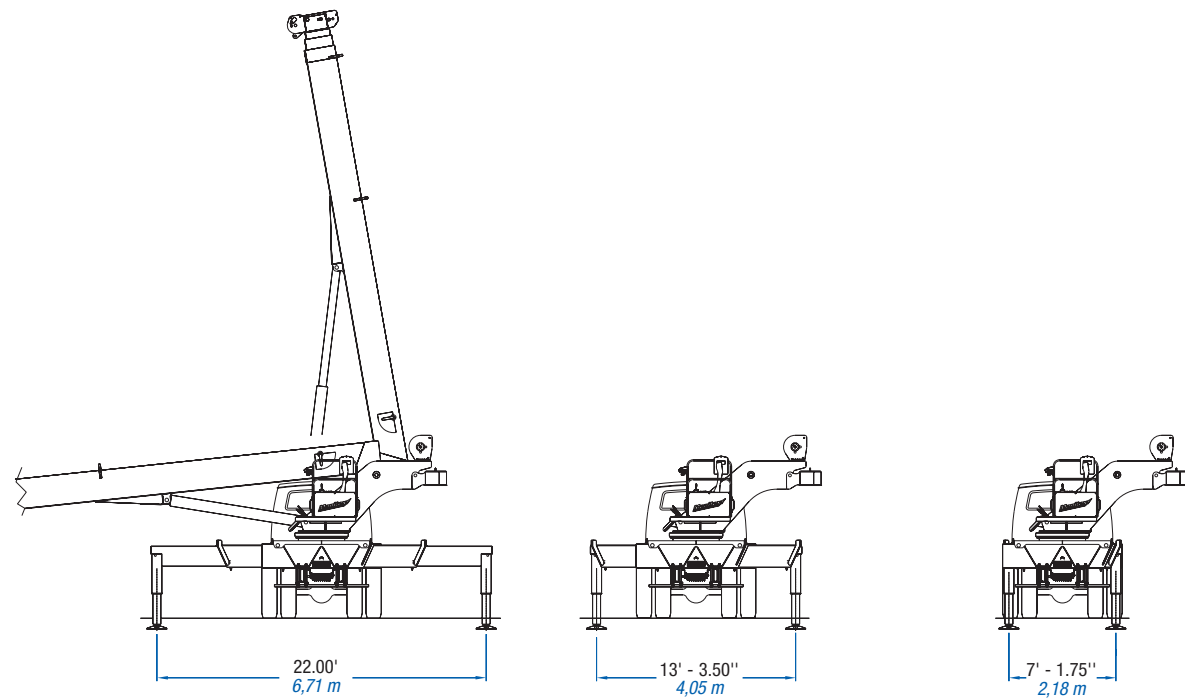

FULL SPREAD

INTERMEDIATE SPREAD

RETRACTED SPREAD

MAXIMUM TIP HEIGHT	3877S/SHL	38100S/SHL	38124S/SHL
Configuration	Boom 77' 23,5 m	Boom 100' 30,5 m	Boom 124' 37,8 m
Extended Boom	86' 5" 26,3 m	109' 2" 33,3 m	132' 4" 40,3 m
Fixed or Retracted Jib	—	140' 0" 42,7 m	163' 7" 49,9 m
Extended Jib	—	164' 8" 50,2 m	—

WEIGHTS	3877S	38100S	38124S	3877SHL	38100SHL	38124SHL
Cab Alone	575 lb 261 kg	575 lb 261 kg	575 lb 261 kg	575 lb 261 kg	575 lb 261 kg	575 lb 261 kg
Crane without Cab	28,806 lb 13 066 kg	29,733 lb 13 847 kg	31,329 lb 14 211 kg	34,535 lb 15 664 kg	35,826 lb 16 251 kg	37,246 lb 16 895 kg
Flat Bed 10' (3,10 m)	1,000 lb 454 kg	1,000 lb 454 kg	1,000 lb 454 kg	—	—	—
Flat Bed 8' (2,40 m)	—	—	—	750 lb 340 kg	750 lb 340 kg	750 lb 340 kg
Fixed Jib 30'6" (9,30 m)	—	1,126 lb 511 kg	—	—	1,126 lb 511 kg	—
Fixed Jib 31' (9,50 m)	—	—	850 lb 386 kg	—	—	850 lb 386 kg
Telescopic Jib 30'6"–55' (9,3m – 16,8m)	—	1,754 lb 796 kg	—	—	1,754 lb 796 kg	—

USE THIS CHART ONLY WHEN OUTRIGGERS ARE FULLY EXTENDED.

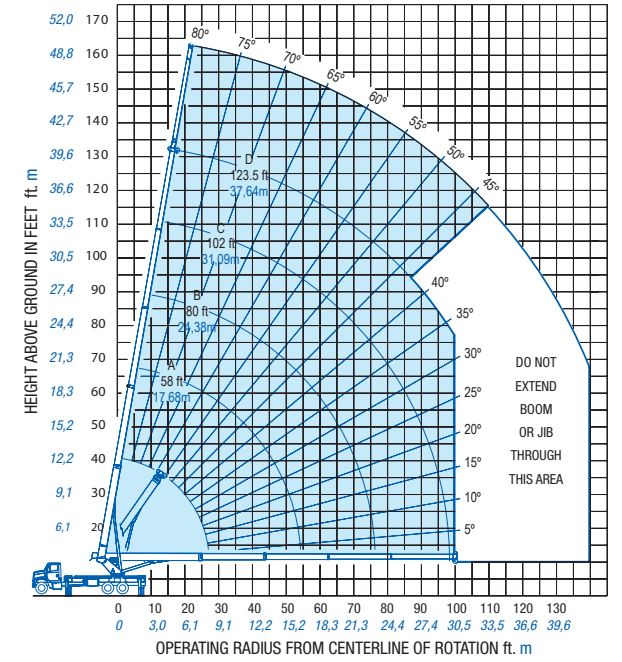
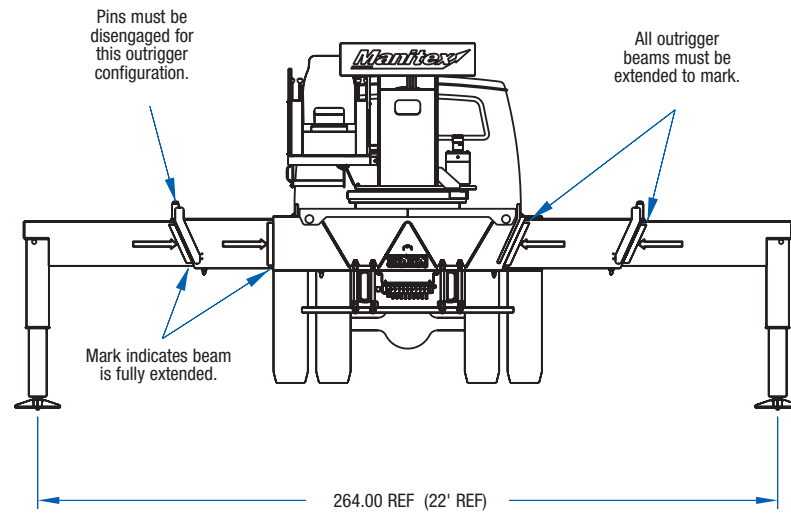

FULLY EXTENDED OUTRIGGER SPREAD: MODEL 38124S

MAIN BOOM LOAD RATINGS															JIB			
Operating Radius	Boom Length		A		B		C		D		Fixed Jib							
	30.8 Feet 9,40 Meters	58 Feet 17,68 Meters	80 Feet 24,38 Meters	102 Feet 31,09 Meters	123.5 Feet 37,64 Meters	31 Feet 9,50 Meters												
Feet Meters	lb. kg.	lb. kg.	lb. kg.	lb. kg.	lb. kg.	lb. kg.	lb. kg.	lb. kg.	lb. kg.	lb. kg.	lb. kg.	lb. kg.	lb. kg.					
5	75	76,000	34 473															
8	69	60,500	27 442															
10	64	52,550	23 836															
12	60	46,600	21 137	75	25,000	11 340												
15	53	39,600	17 962	73	25,000	11 340	79	21,500	9 752									
20	40	30,300	13 744	67	25,000	11 340	75	19,700	8 936	80	14,500	6 577						
25	22	23,070	10 464	62	22,840	10 360	71	18,200	8 255	77	13,500	6 123	80	8,450	3 833			
30				56	18,670	8 469	67	16,250	7 371	74	12,820	5 815	78	8,150	3 697	80	4,000	1 814
35				49	14,450	6 554	63	14,540	6 595	71	11,380	5 162	75	7,800	3 538	78	3,850	1 746
40				42	11,190	5 076	59	11,490	5 212	68	10,160	4 608	72	7,280	3 302	76	3,700	1 678
45				34	8,820	4 001	54	9,110	4 132	65	9,250	4 196	70	6,780	3 075	74	3,550	1 610
50				23	7,030	3 189	50	7,340	3 329	61	7,480	3 393	67	6,160	2 794	72	3,400	1 542
55							44	5,970	2 708	58	6,110	2 771	65	5,540	2 513	70	3,250	1 474
60							39	4,880	2 214	54	5,020	2 277	62	5,000	2 268	68	3,080	1 397
65							32	3,980	1 805	50	4,130	1 873	59	4,200	1 905	66	2,910	1 320
70							24	3,230	1 465	46	3,390	1 538	56	3,460	1 569	64	2,750	1 247
75							12	2,580	1 170	42	2,760	1 252	53	2,830	1 284	62	2,600	1 179
80										37	2,220	1 007	50	2,300	1 043	60	2,460	1 116
85										32	1,750	794	47	1,840	835	58	2,260	1 025
90										25	1,340	608	43	1,430	649	55	1,850	839
95										17	970	440	40	1,070	485	53	1,490	676
100													35	750	340	51	1,170	531
105																48	880	399
110																45	620	281
		450 lbs 204 kg	240 lbs 109 kg	180 lbs 82 kg	140 lbs 64 kg	120 lbs 54 kg	DEDUCTIONS FOR STOWED JIB											

Meets ANSI B30.5 Requirements - Do not operate crane or accessories within 10' (3,05m) of live power lines.
 NOTICE: This chart is for reference only and must not be used for lifting purposes. Consult factory for other boom options.